

FULL LINE CATALOG

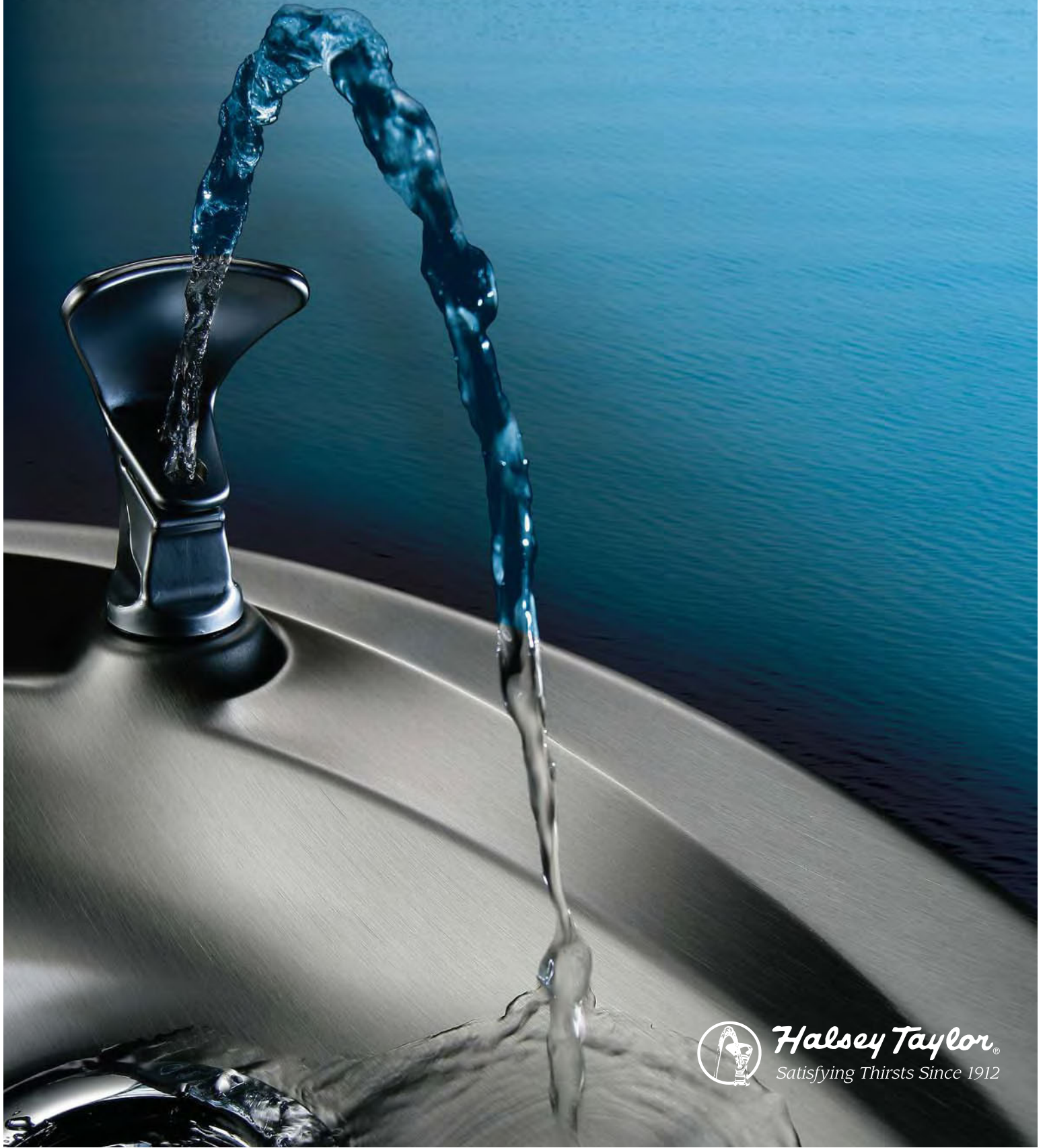

Halsey Taylor[®]
Satisfying Thirsts Since 1912

Halsey Taylor...

We Have The Solution, Inside and Out!

Halsey W. Taylor made the decision to dedicate his life to providing a safe drink of water in public places in 1912, when he developed the *Puritan* sanitary drinking fountain. The rest, as they say, is history, and while we are extremely proud of the many innovations that are associated with the Halsey Taylor name, we have never lost focus of our original mission of providing the safest drink of water possible.

Today, more than ever, Halsey Taylor offers water coolers and drinking fountains for just about any application. From our new **energy efficient GreenSpec® listed coolers**, to our **Voyager™ MVP with Filter Life indicator**, you can count on Halsey Taylor to deliver a satisfying drink with style, both indoors and out! And you can count on Halsey Taylor to keep delivering unique product features, such as Personalized In-Mold Graphics on Voyager™ Water Coolers!

Company logos, team emblems, advertisements and public service announcements, **can be molded into Voyager's top panel** for lasting impressions. And the cooler top can be easily removed and replaced, allowing for messages and designs to be rotated or changed with little effort.

Halsey Taylor would like to thank you for your continued trust and support. As always, exciting new products and innovations will be a part of our future. But more importantly, just as it's been since 1912, our number one priority will always be the safety of those who drink from our water coolers and drinking fountains. We're certain Halsey W. Taylor would be proud.

Puritan™ Filtered Coolers (see pages 10 & 12) are equipped with a lead reduction system designed to remove cysts, lead particles and chlorine.

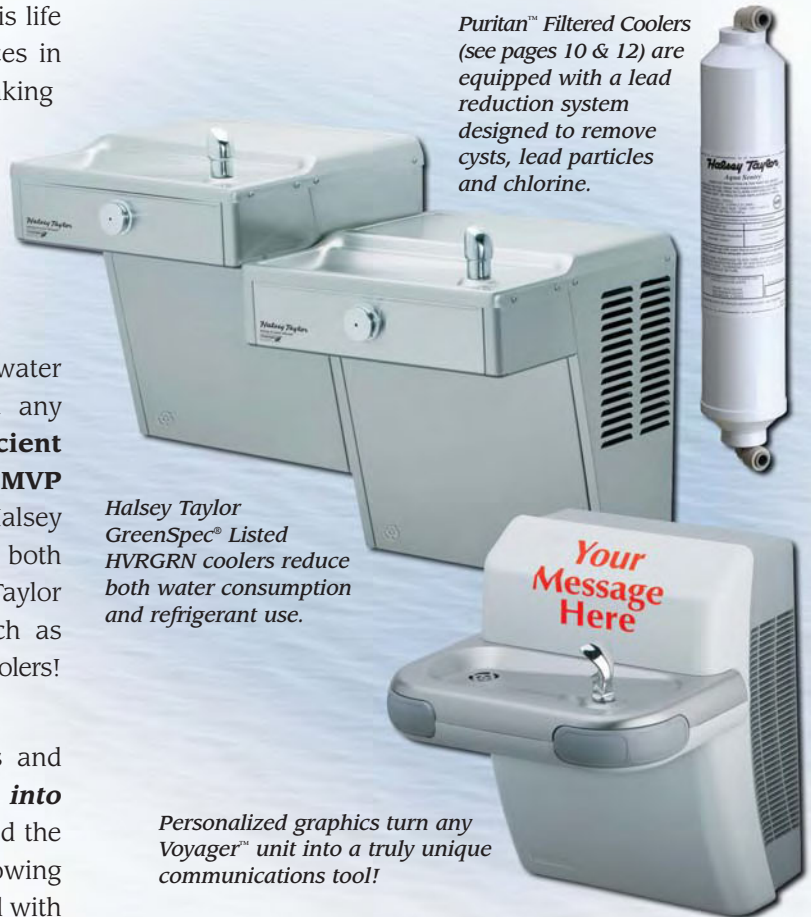

Halsey Taylor GreenSpec® Listed HVRGRN coolers reduce both water consumption and refrigerant use.

Personalized graphics turn any Voyager™ unit into a truly unique communications tool!

TABLE OF CONTENTS

ADA COMPLIANT WATER COOLERS	3-11
PURITAN™ FILTERED UNITS	10 & 12
STANDARD WATER COOLERS	11-15
ADA COMPLIANT DRINKING FOUNTAINS	16-21
STANDARD DRINKING FOUNTAINS	22-26
FOUNTAIN KITS	27
BRACKET FOUNTAINS	27
REMOTE CHILLERS	28
ACCESSORIES	28-29
FEATURE, COLOR AND SIZING GUIDES	30-31



All Halsey Taylor cataloged drinking water system components are certified to NSF/ANSI 61. Halsey Taylor Water Coolers are designed to meet ARI Standard 1010.

Note: This catalog supercedes all previously printed catalogs.

HVRGRN GreenSpec® Listed Water Coolers

ADA COOLERS



HVRGRN Series GreenSpec® Listed Water Coolers



- More than 50% greater energy efficiency ▲
- Low-flow bubbler reduces water usage by almost 40% ▲
- Reduces refrigerant use by nearly 8% ▲
- Produced from 60% recycled content stainless steel
- Stainless steel satin finish resists corrosion
- U.L. listed for indoor and outdoor service

- Can be installed to meet adult or child ADA
- Chrome-plated vandal-resistant bubbler
- Vandal-resistant pushbutton
- Vandal-resistant pinned torx screws
- Optional water filter and glass filler package (HVRGRN8-GFWF and HVRGRN8BL-GFWF) factory installed

▲ Over average market performance

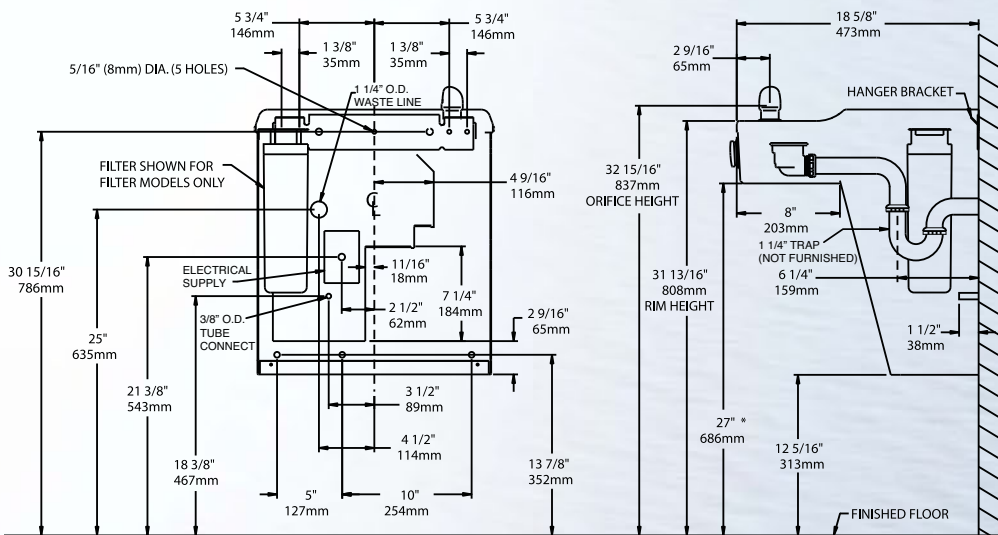

* Adult ADA requirement. 24" (609mm) for child ADA. Adjust all other measurements accordingly.

Model	Rated GPH Cooled to 50° F.	Rated Watt Usage	F.L. Amps	Condenser Cooling	Shipping Weight (lbs.)
HVRGRN8	8.0	260	2.8	Air	66
HVRGRN8BL	8.0	260	2.8	Air	94
HVRGRN8-GFWF†	8.0	260	2.8	Air	70
HVRGRN8BL-GFWF†	8.0	260	2.8	Air	98

† Includes water filter and glass filler factory installed



MVP Series Water Coolers with Filter Life Monitor

ADA COOLERS



Voyager™ MVP Hands-Free Water Coolers with Filter Life Monitor



- **LED display tells you that water is being filtered, and indicates when the filter needs replacing**
- Electronic sensor provides **hands-free, sanitary operation**
- **Aqua Sentry Filter** reduces lead, cysts, chlorine and particulates for up to 750 gallons of use
- Provides bottle water quality at a fraction of the cost, with no plastic container waste
- Designed with educational and healthcare facilities in mind
- Cabinet molded from durable polymer
- Impact and scratch resistant
- Resistant to moisture, heat and sunlight
- Standard finish is Two-Tone Gray
- Available in 220V/50Hz and 220V/60Hz
- Bi-level unit (HTVBLEE-MVP-Q) features display and sensor on right hand unit
- **ADA Compliant** for both **children and adults**

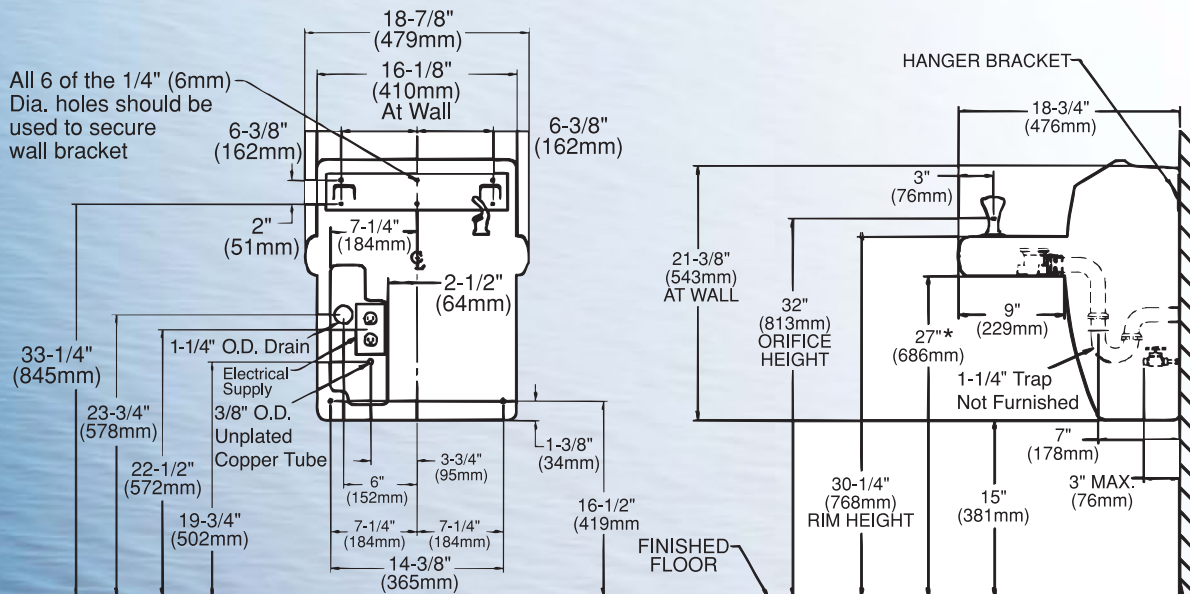

* Adult ADA requirement. 24" (609mm) for child ADA. Adjust all other measurements accordingly.

Model	Rated GPH Cooled to 50° F.	Rated Watt Usage	E.L. Amps	Condenser Cooling	Shipping Weight (lbs.)
HTV8EE-MVP-Q	7.6	370	4.0	Air	51
HTV8BLEE-MVP-Q	7.6	370	4.0	Air	80

Voyager™ Series Barrier-Free Water Coolers

ADA COOLERS



HTV8BL-Q



HTV8-Q



HTV Series Water Coolers

- Ultra modern design
- Cabinet molded from durable polymer
- Impact and scratch resistant
- Resistant to moisture, heat and sunlight
- Standard finish is Two-Tone Gray
- Stainless Steel Basin with Integral Strainer
- No exposed sharp corners or edges
- *Easy-Touch* self-closing push bars
- Large opening for easy installation



- Front panels remove for easy service and maintenance
- *ADA Compliant* for both **children and adults**
- Exclusive! Halsey Taylor *Double Bubbler™*
- Available with electronic sensors (HTV8EE-Q and HTV8BL-EE-Q)
- Optional glass filler factory installed only (HTV8-GF-Q and HTV8BL-GF-Q)
- Optional water filter factory installed (see Puritan™ Coolers, page 10)

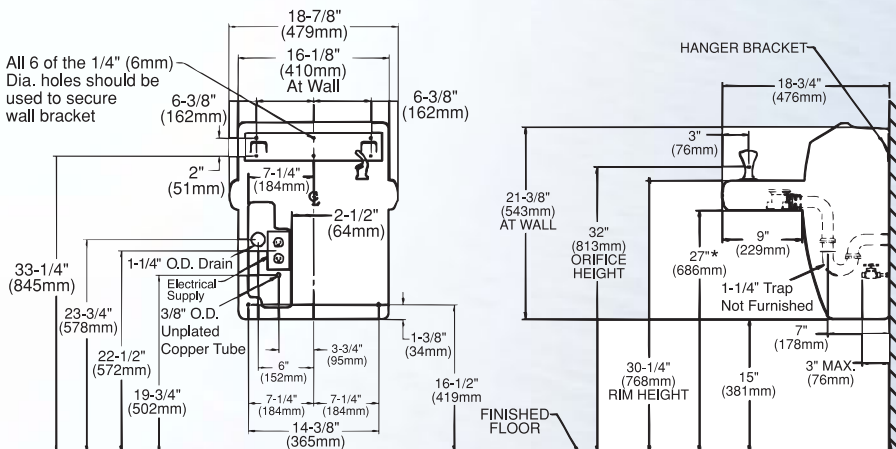

* Adult ADA requirement. 24" (609mm) for child ADA. Adjust all other measurements accordingly.

Model	Rated GPH Cooled to 50° F.	Rated Watt Usage	F.L. Amps	Condenser Cooling	Shipping Weight (lbs.)
HTV4-Q	4.0	370	4.0	Air	51
HTV8-Q	7.6	370	4.0	Air	51
HTV8EE-Q	7.6	370	4.0	Air	51
HTV8BL-Q	7.6	370	4.0	Air	78
HTV8BL-EE-Q	7.6	370	4.0	Air	80

HVR Series Vandal-Resistant Child ADA Water Coolers

ADA COOLERS



HVR8 ADA



HVR Series Water Coolers

- Stainless steel satin finish resists stains and corrosion
- **U.L. listed for indoor and outdoor service**
- Can be installed to meet **adult or child ADA**
- Chrome-plated vandal-resistant bubbler
- Vandal-resistant pushbutton does not require grasping or twisting
- Vandal-resistant pinned torx screws



- Optional lower screens discourage tampering
- Optional water filter factory installed (see Puritan™ Coolers, page 10)
- **Available with 220-240 volt option**
- **Available as Frost Resistant Models (HVR8FR ADA and HVR8BLFR ADA)**
- Ideal for schools, stadiums, recreational facilities, golf courses and other rigorous, high-traffic applications



HVR8BL ADA

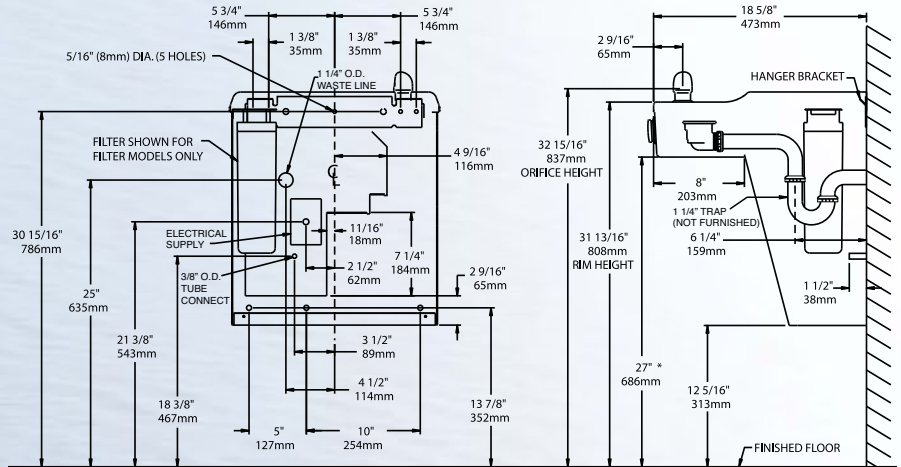

* Adult ADA requirement. 24" (609mm) for child ADA. Adjust all other measurements accordingly.

Model	Rated GPH Cooled to 50° F.	Rated Watt Usage	F.L. Amps	Condenser Cooling	Shipping Weight (lbs.)
HVR8 ADA	8.0	370	4.0	Air	66
HVR8FR ADA	8.0	620	6.2	Air	68
HVR8 ADA 220-240V 50Hz	6.7	370	2.0	Air	66
HVR8 ADA 220-240V 60Hz	8.0	370	2.0	Air	66
HVR8BL ADA	8.0	370	4.0	Air	94
HVR8BLFR ADA	8.0	620	6.2	Air	96
HVR8BL ADA 220-240V 50Hz	6.7	370	2.0	Air	94
HVR8BL ADA 220-240V 60Hz	8.0	370	2.0	Air	94

HAC ADA Water Coolers



HAC8FS-Q ADA Water Cooler

- Exclusive Halsey Taylor *Double Bubbler™*
- Fine mesh strainer on water inlet line
- Easy-to-operate front and side pushbars with raised letters for the visually impaired
- Large backplate opening for easier rough-ins
- Access to trap without removing side panels
- Durable satin finish stainless steel
- Available with **optional platinum vinyl finish**
- Available with electronic sensor (HAC8EE-Q ADA)
- Available without refrigeration (HACFS L/R ADA)
- Can be installed to meet **adult or child ADA**
- Available with Easy-Flex™ Bubbler or vandal-resistant bubbler
- Optional water filter factory installed, (see Puritan™ Coolers, page 10)



HAC8FS-Q ADA



HAC8FSBL-Q ADA
With Optional
Platinum Vinyl Finish

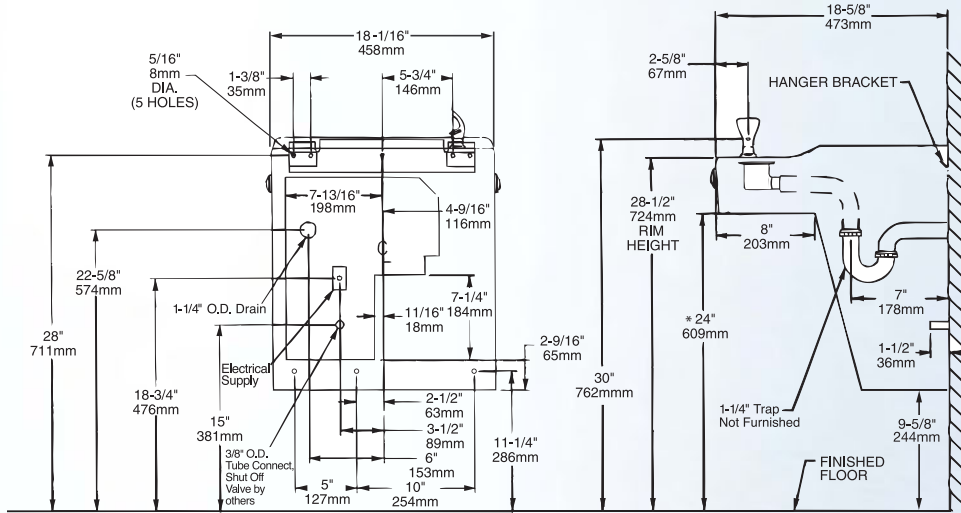

* Child ADA requirement. 27" (686mm) for Adult ADA. Adjust other measurements accordingly.

Barrier-Free Water Cooler with Back Splash

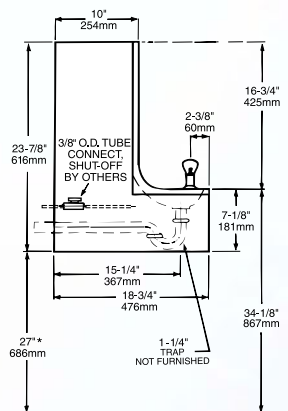

WC8FS-Q Water Cooler

- One-piece stainless steel backsplash and basin
- Exclusive! Halsey Taylor *Double Bubbler™*
- Front and side pushbars with raised letters for the visually impaired
- Standard finish is Platinum Vinyl
- Optional finishes available
- Available without refrigeration (WCFS L/R)
- Available with Easy-Flex™ Bubbler
- Meets requirements of ADA



WC8FS-Q

Model	Rated GPH Cooled to 50° F.	Rated Watt Usage	F.L. Amps	Condenser Cooling	Shipping Weight (lbs.)
HAC8FS-Q ADA	8.0	370	4.0	Air	72
HAC8EE-Q ADA	8.0	370	4.0	Air	71
HAC8FSBL-Q ADA	8.0	370	4.0	Air	93
HAC8BL-EE-Q ADA	8.0	370	4.0	Air	100
WC8FS-Q	7.6	370	4.0	Air	70

Contour™ Series Barrier-Free Water Coolers

ADA COOLERS



HCRFER-Q

HCRFER-Q Water Cooler

- Meets requirements of **child ADA**
- Softly rounded corners
- Exclusive! Halsey Taylor *Double Bubbler™*
- Durable satin finish stainless steel
- Easy-to-operate pushbuttons
- Open mounting frame design for ease of installation
- Panels overlap wall face and removable louvered front panel makes servicing easy



HRFER-Q Water Cooler

- Softly rounded corners
- Extended barrier-free design
- Exclusive! Halsey Taylor *Double Bubbler™*
- Standard finish is satin finish stainless steel
- Easy-to-operate pushbuttons
- Open mounting frame design
- Basins Available in Galaxy Gray and Black Onyx Marblyte™*
- Meets requirements of ADA
- Available as single barrier-free unit (HRFER-Q)
- Available with Electronic Sensor (HRFER-EE-Q and HRFER-EE-Q, Stainless Steel only)

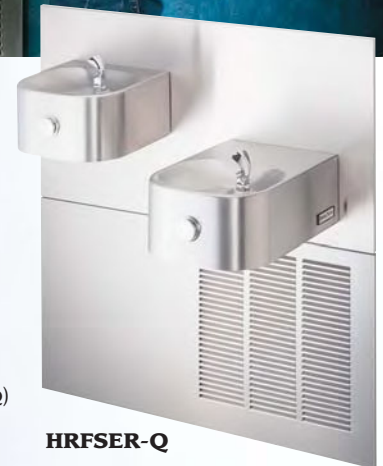

HRFSER-Q

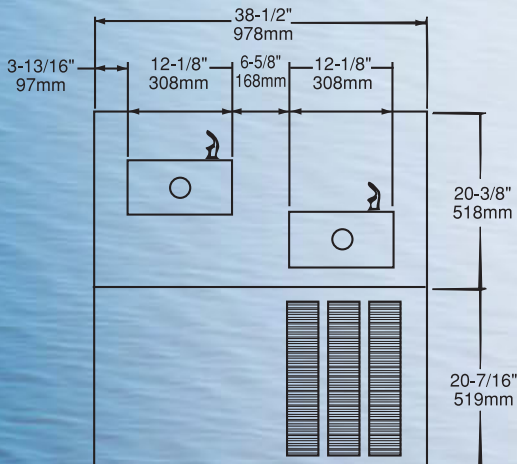

HRFGER-Q
With Galaxy Gray
Marblyte™ Basin



HRFER-EE-Q

Model	Rated GPH Cooled to 50° F.	Rated Watt Usage	F.L. Amps	Condenser Cooling	Shipping Weight (lbs.)
HCRFER-Q	7.5	370	4.0	Air	99
HRFER-Q	7.5	370	4.0	Air	100
HRFER-EE-Q	7.5	370	4.0	Air	100
HRFSER-Q	7.5	370	4.0	Air	136
HRFSER-EE-Q	7.5	370	4.0	Air	136

OVL-II™ Series Barrier-Free Water Coolers

ADA COOLERS



OVL-II™ SER-Q
(Shown with Black Onyx Marblyte™ basins)



OVL-II™ SER-EE-Q



OVL-II™ ER-Q

OVL-II™ Series Water Cooler

- Sophisticated oval styling
- Bi-level models feature twin basins, including an extended barrier-free design
- Exclusive! Halsey Taylor *Double Bubbler™*
- Standard finish is satin finish stainless steel
- Semi-circular 180° pushbars for ease of operation
- Available with *Galaxy Gray and Black Onyx Marblyte™ basins.*
- Panels overlap wall face and removable louvered front panel makes servicing easy
- Available as single barrier-free unit (OVL-II™ER-Q)
- Meets requirements of ADA
- Available with Electronic Sensor (OVL-II™SEREE-Q and OVL-II™EREE-Q)

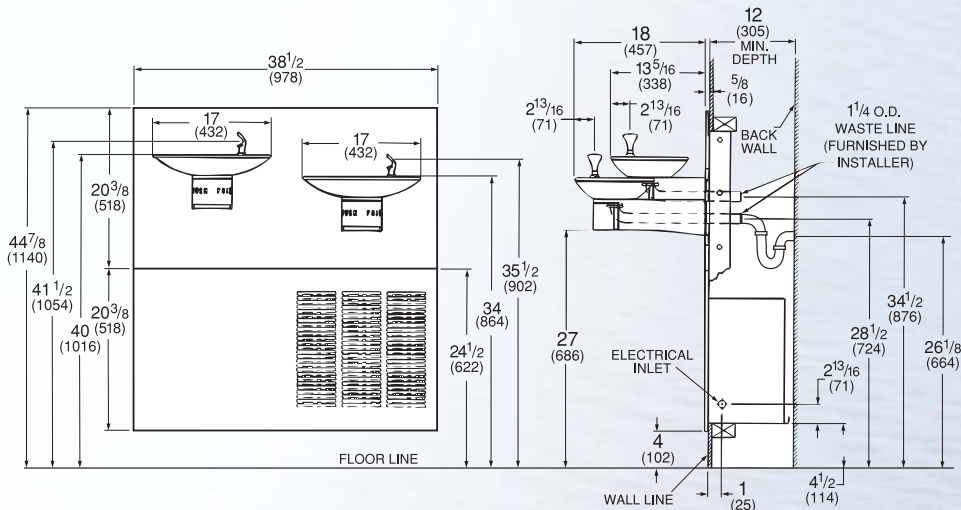

Model	Rated GPH Cooled to 50° F.	Rated Watt Usage	F.L. Amps	Condenser Cooling	Shipping Weight (lbs.)
OVL-II™ER-Q	7.5	370	4.0	Air	96
OVL-II™ER-EE-Q	7.5	370	4.0	Air	101
OVL-II™SER-Q	7.5	370	4.0	Air	135
OVL-II™SER-EE-Q	7.5	370	4.0	Air	140

Puritan™

Filtered Coolers

ADA COOLERS



HTV8BL-WF-Q



HTV8BL-WF-Q Barrier-Free Bi-Level Wall-Mount Water Filtered Cooler

- Equipped with lead reduction system designed to remove cysts, lead particles and chlorine
- Exclusive! Halsey Taylor *Double Bubbler™*
- ADA compliant for both **children and adults**
- Impact and scratch resistant
- Large backplate opening for easier rough-ins
- Standard finish is two-tone gray polymer
- Available as single barrier-free unit (HTV8-WF-Q)

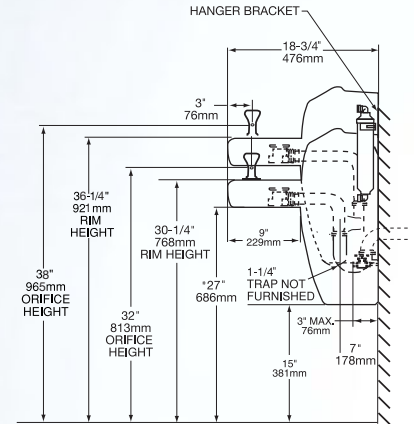

HVR8-WF ADA



HVR8-WF Vandal-Resistant Water Filtered Cooler

- Equipped with lead reduction system designed to remove cysts, lead particles and chlorine
- Chrome-plated vandal-resistant bubbler
- **U.L. listed for indoor and outdoor service**
- ADA compliant for both **children and adults**
- Rugged stainless steel satin finish
- Available as bi-level barrier-free unit (HVR8BL-WF ADA)

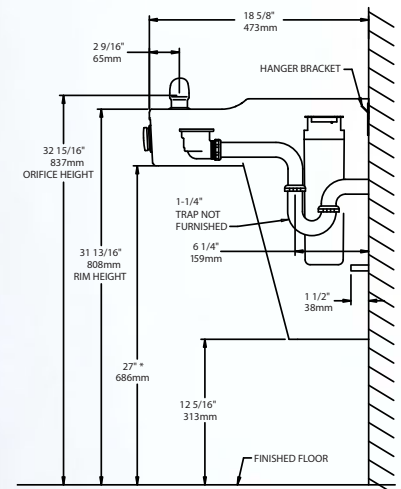

HAC8FSBL-WF-Q ADA



HAC8FSBL-WF-Q ADA Bi-Level Water Filtered Cooler

- Equipped with lead reduction system designed to remove cysts, lead particles and chlorine
- Exclusive! Halsey Taylor *Double Bubbler™*
- ADA compliant for both **children and adults**
- Durable satin finish stainless steel
- Available with **optional platinum vinyl finish**
- Available as single barrier-free unit (HAC8FS-WF-Q ADA)

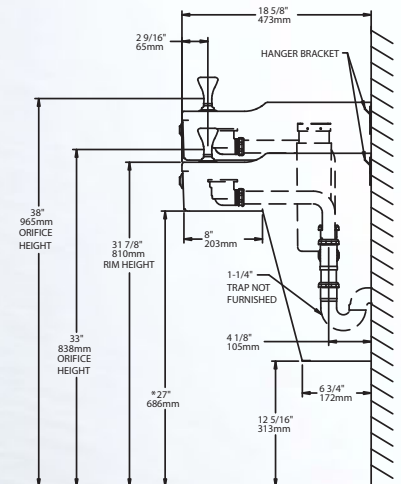

Model	Rated GPH Cooled to 50° F.	Rated Watt Usage	F.L. Amps	Condenser Cooling	Shipping Weight (lbs.)
HTV8-WF-Q	7.6	370	4.0	Air	53
HTV8BL-WF-Q	7.6	370	4.0	Air	80
HVR8-WF ADA	7.8	370	4.0	Air	68
HVR8BL-WF ADA	7.8	370	4.0	Air	96
HAC8FS-WF-Q ADA	8.0	370	4.0	Air	74
HAC8FSBL-WF-Q ADA	8.0	370	4.0	Air	95

Fully Recessed Barrier-Free Water Cooler



BFMR-Q

BFMR-Q Water Cooler

- Fully-recessed opening provides uninterrupted corridor space and access for the handicapped
- Exclusive! Halsey Taylor *Double Bubbler™*
- Durable satin finish stainless steel
- Removable louvered panel mounts above basin for barrier-free installation
- Optional pushbutton glass filler factory installed
- Available without refrigeration (BFM L/R)
- Available with Easy-Flex™ Bubbler
- Meets requirements of ADA

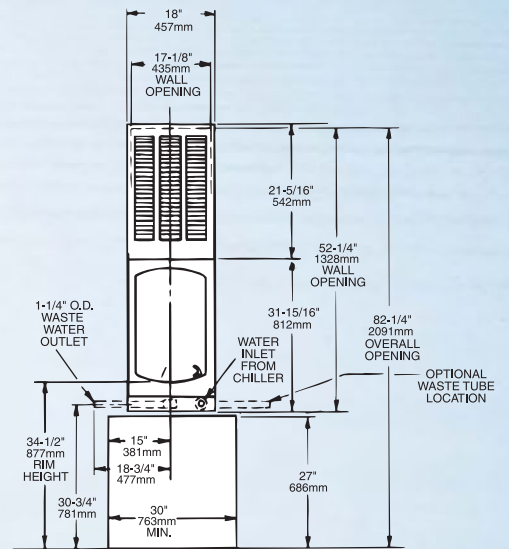

ADA COOLERS

Fully & Simulated Recessed Standard Water Coolers



RC8A-Q

RC8A-Q Water Cooler

- Ideal for high-traffic areas
- Exclusive! Halsey Taylor *Double Bubbler™*
- Durable satin finish stainless steel
- Optional pushbutton glass filler available factory installed
- Removable louvered bottom panel for easy service
- Available with optional Cup Dispenser/Glass Filler (14700) or with optional Cup Dispenser only (14762)
- Available with Easy-Flex™ Bubbler

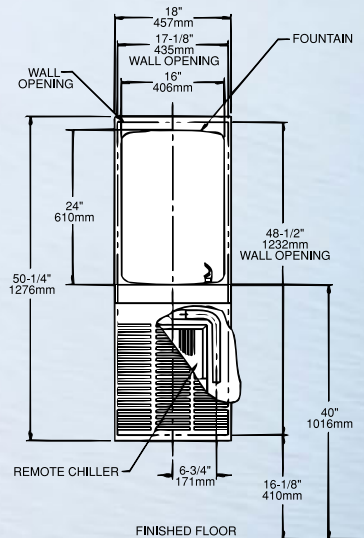

STANDARD COOLERS



HBW8A-Q

HBW8A-Q

- Extends only 9 1/2" from the wall face
- Front pushbutton
- Exclusive! Halsey Taylor *Double Bubbler™*
- Provides recessed appearance without entering the wall
- Easy-clean basin with anti-splash rim
- Available with Easy-Flex™ Bubbler
- Optional finishes available
- Standard finish is Platinum Vinyl cabinet with stainless steel basin
- Available without refrigeration (HBW L/R)

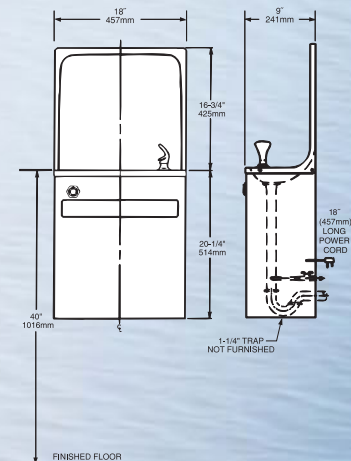

Model	Rated GPH Cooled to 50° F.	Rated Watt Usage	F.L. Amps	Condenser Cooling	Shipping Weight (lbs.)
BFMR-Q	7.5	370	4.0	Air	91
RC8A-Q	7.5	370	4.0	Air	89
HBW8A-Q	7.5	370	4.0	Air	69



Standard Water Filtered Coolers



WM8A-WF-Q

Wall Mounted Standard Water Filtered Cooler

- Equipped with lead reduction system designed to remove cysts, lead particles and chlorine
- Exclusive! Halsey Taylor *Double Bubbler™*
- Easy-clean, anti-splash rim basin
- Mounts with all connections concealed
- Glass filler kits available
- Standard finish is Platinum Vinyl cabinet with stainless steel basin
- Optional finishes available

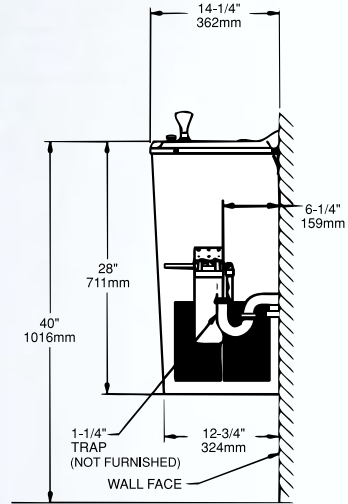

SCWT-8A-WF-Q

Free Standing Standard Water Filtered Cooler

- Equipped with lead reduction system designed to remove cysts, lead particles and chlorine
- Exclusive! Halsey Taylor *Double Bubbler™*
- Glass filler and foot pedal kits available
- Factory-installed coffee server (CB) available
- Installs free standing or wall tight
- Standard finish is Platinum Vinyl cabinet with stainless steel basin
- Optional finishes available

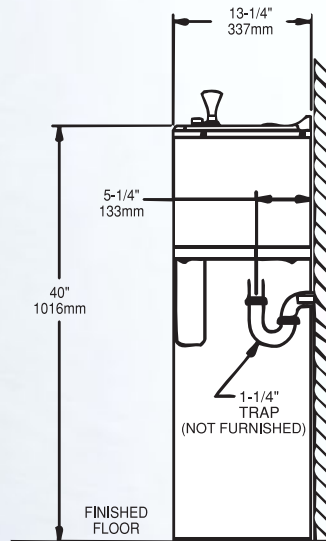

Model	Rated GPH Cooled to 50° F.	Rated Watt Usage	F.L. Amps	Condenser Cooling	Shipping Weight (lbs.)
WM8A-WF-Q	7.6	370	4.0	Air	72
SCWT8A-WF-Q	7.6	370	4.0	Air	76

Deluxe Floor-Standing Water Coolers



SCWT

SCWT4A-Q • SCWT8A-Q SCWT14A-Q • SCWT14W-Q

- Exclusive! Halsey Taylor *Double Bubbler™*
- Glass filler and foot pedal kits available
- Factory-installed coffee server (CB) available (for SCWT8A-Q and SCWT14A-Q only)
- Standard finish is Platinum Vinyl
- Available with Easy-Flex™ Bubbler
- Optional finishes available
- Optional water filter factory installed (see Puritan™ coolers, page 12)
- Installs free standing or wall tight
- Available without refrigeration (SCWT L/R)



Optional factory installed coffee bar

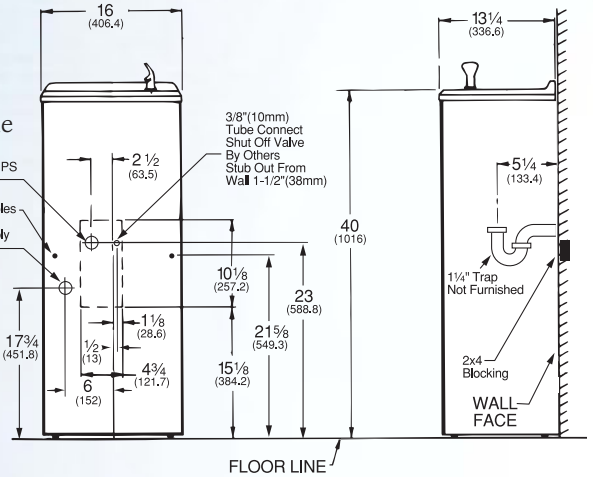

XP8W-Q

XP8W-Q Explosion Proof Cooler

- U.L. listed for hazardous locations
- Durable satin finish stainless steel only



Economy Floor-Standing Water Coolers



S Series

S300-2E-Q • S500-5E-Q S1000-10E-Q

- Exclusive! Halsey Taylor *Double Bubbler™*
- Available in Platinum Vinyl and stainless steel
- Available without refrigeration (SD L/R)

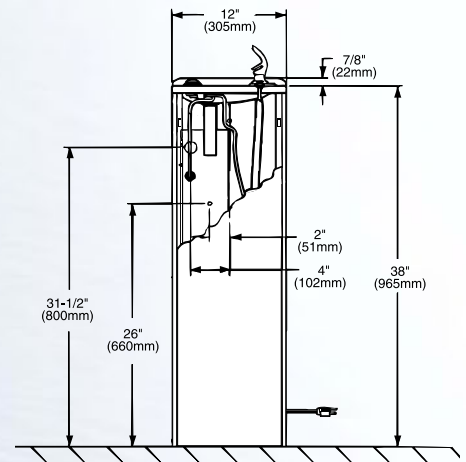

Model	Rated GPH Cooled to 50° F.	Rated Watt Usage	F.L. Amps	Condenser Cooling	Shipping Weight (lbs.)
SCWT4A-Q	4.0	230	2.5	Air	72
SCWT8A-Q	7.6	370	4.0	Air	73
SCWT8-CB-Q	7.6	1120	10.5	Air	76
SCWT14A-Q	13.5	690	7.5	Air	76
SCWT14W-Q	14.0	600	6.5	Water	77
XP8W-Q	8.0	370	4.0	Water	84
S300-2E-Q	2.8	230	2.5	Air	54
S500-5E-Q	5.0	230	2.5	Air	60
S1000-10E-Q	9.8	535	5.8	Air	69

Deluxe and Compact Wall-Mounted Water Coolers

STANDARD COOLERS

WM8A-Q • WM14A-Q • WM14W-Q

- Attractive styling blends with any decor
- Exclusive! Halsey Taylor *Double Bubbler™*
- Easy-clean, anti-splash rim basin
- Mounts with all connections concealed
- Glass filler kits available
- Standard finish is Platinum Vinyl cabinet with stainless steel basin
- Optional water filter factory installed (see Puritan™ coolers, page 12)
- Available with Easy-Flex™ Bubbler
- Optional finishes available
- Available without refrigeration (WM L/R)



WM Series

Note: SW Series dimensions, same as WM Series but with 23" height.

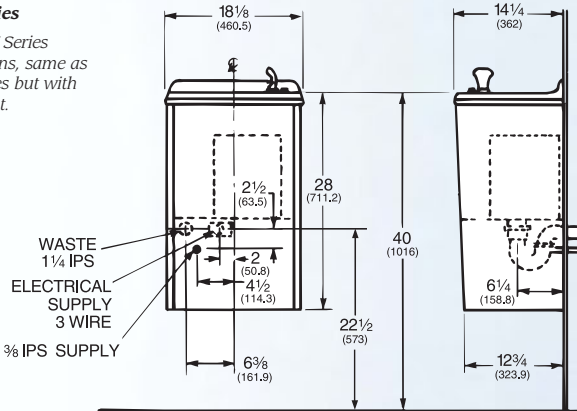

WM Series

SW4A-Q • SW8A-Q SW14A-Q

Same as WM Series but with space-saving 23" high cabinet (shown in Slate Vinyl)



SW Series

Deluxe Bi-Level Wall-Mounted Water Cooler

WM14ABL-Q

- Ideal for elementary schools, retail stores and other public environments
- Exclusive! Halsey Taylor *Double Bubbler™*
- Easy-clean, anti-splash rim basin
- Factory-supplied cabinet-to-cabinet mounting system
- Glass filler kits available
- Standard finish is Platinum Vinyl cabinet with stainless steel basin
- Optional finishes available
- Available with Easy-Flex™ Bubbler

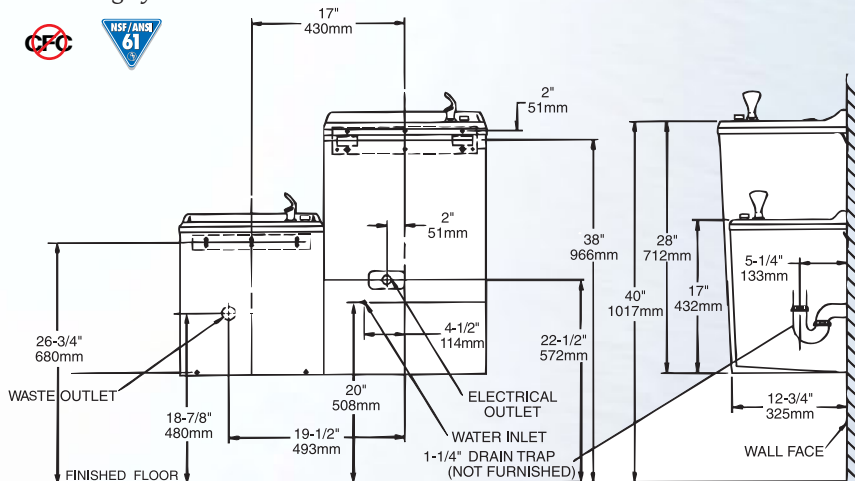

WM14ABL-Q

Model	Rated GPH Cooled to 50° F.	Rated Watt Usage	F.L. Amps	Condenser Cooling	Shipping Weight (lbs.)
SW4A-Q	4.0	230	2.5	Air	60
SW8A-Q	7.6	370	4.0	Air	68
SW14A-Q	13.5	690	7.5	Air	70
WM8A-Q	7.6	370	4.0	Air	69
WM14A-Q	13.5	690	7.5	Air	74
WM14W-Q	14.0	600	6.5	Water	75
WM14ABL-Q	13.5	690	7.5	Air	96

Contour™ Series Barrier-Free Drinking Fountains

ADA FOUNTAINS



HDFBLEBP



HDFFEBP



HDFFBLEBP



HDF Heavy Duty Drinking Fountains



- 14-gauge heavy-duty satin finish stainless steel resists stains and corrosion
- Chrome-plated vandal-resistant bubbler
- Flat, one-piece vandal-resistant drain is less prone to tampering
- Over-sized seamless drawn basin with contoured corners and edges for reduced splatter and added safety
- Can be installed to meet **adult or child ADA**
- Large self-closing, vandal-resistant pushbutton does not require grasping or twisting
- Freeze-resistant option
- Ideal for schools, stadiums/arenas, shopping malls, airport terminals, recreational building and other rigorous, high-traffic applications

Models HDFFEBP and HDFFBLEBP include trap inside the fountain body and meet adult ADA only.

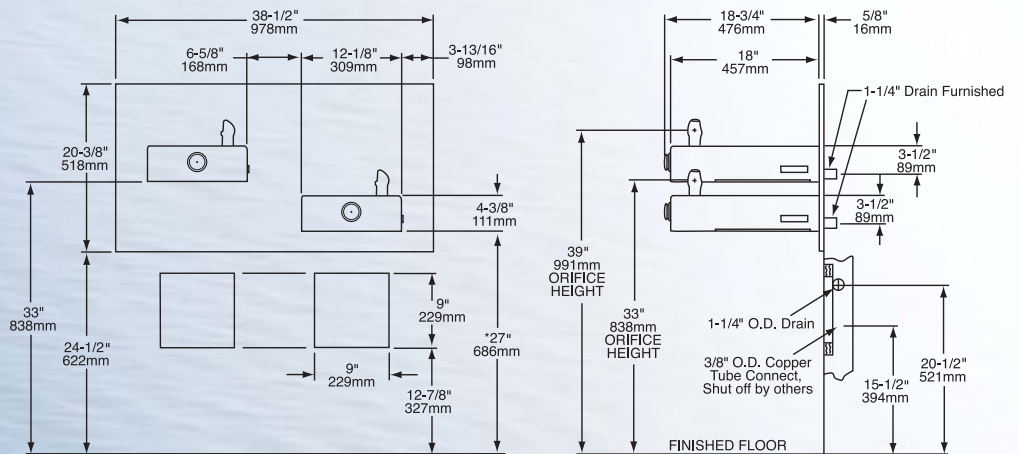

* Adult ADA requirement. 24" (609mm) for child ADA. Adjust all other measurements accordingly.

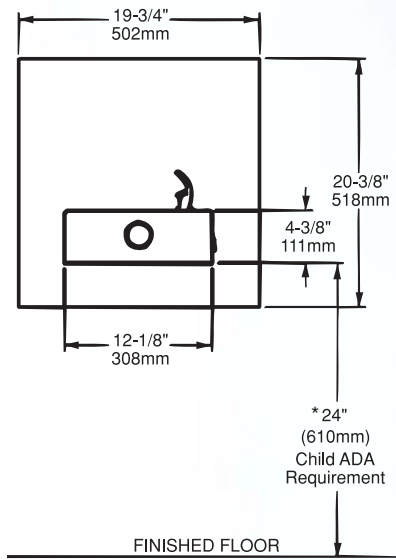

HCRFEBP Drinking Fountain

- Meets requirements of **child ADA**
- Softly rounded corners
- Exclusive! Halsey Taylor *Double Bubbler™*
- Durable satin finish stainless steel
- Easy-to-operate pushbuttons
- Automatic stream regulator



HCRFEBP

ADA FOUNTAINS

* Child ADA requirement. 27" (609mm) for adult ADA. Adjust all other measurements accordingly.

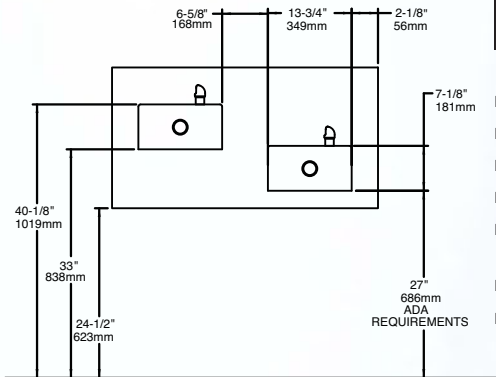

HRFGEBP-VR Drinking Fountain

- Softly rounded corners
- Vandal-Resistant bubblers
- Vandal-Resistant Push Buttons
- *Standard finish is Galaxy Gray Marblyte™*
- Optional in-wall mounting plates and support legs (see page 29)
- Freeze-resistant option
- Meets requirements of ADA



NEW!

HRFGEBP-VR

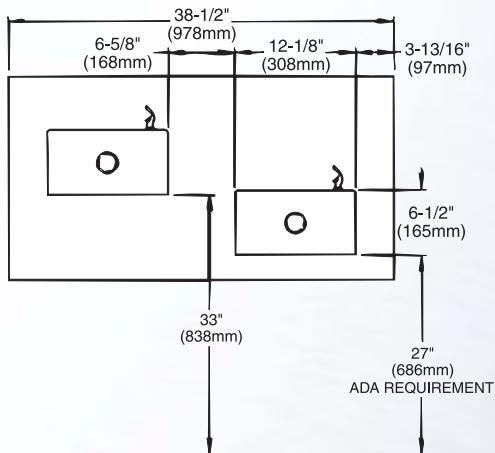

HRFSEBP Bi-Level Drinking Fountain

- Twin basins, including an extended barrier-free design
- Softly rounded corners
- Exclusive! Halsey Taylor *Double Bubbler™*
- Standard finish is satin finish stainless steel
- Available as single barrier-free unit with back panel (HRFEBP) or without back panel (HRFE)
- Meets requirements of ADA
- Available with freeze-resistant valve



HRFSEBP

OVL II™ Barrier-Free Drinking Fountains

ADA FOUNTAINS



OVL-II™ SEBP



OVL-II™ SEBP Drinking Fountain

- Exclusive! Halsey Taylor *Double Bubbler™*
- Standard finish is satin finish stainless steel
- Semi-circular 180° pushbar for ease of use
- Automatic stream regulator
- Available with *Galaxy Gray* and *Black Onyx Marblyte™* basins
- Available as single barrier-free unit with back panel (OVL-II™EBP) or without backpanel (OVL-II™E)
- Meets requirements of ADA
- Available with freeze-resistant valve

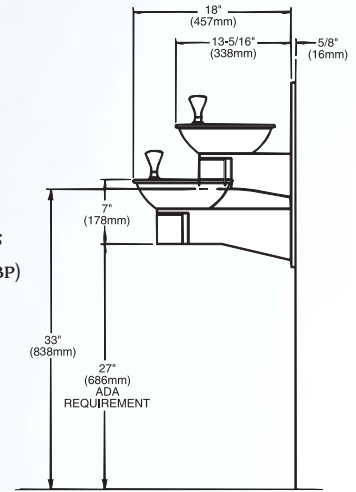

Two Station Marblyte™ Barrier-Free Drinking Fountain



7120 Drinking Fountain

- Ideal for schools and other high-traffic public areas
- Vandal-Resistant Bubblers and bottom cover plate
- Single center drain simplifies both new and retrofit installations
- Softly rounded corners and edges for added style and safety
- Solid one-piece White Granite Marblyte™ construction
- Resists damage and stands-up to heavy, everyday use
- Available with *optional Double Bubblers™*
- Meets requirements of ADA on both sides of unit
- Available with freeze-resistant valve



7120

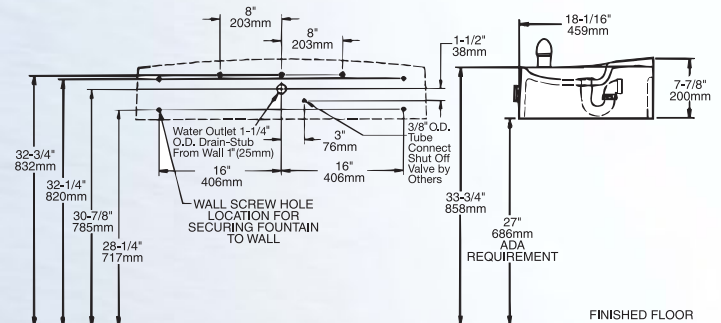

Endura II™ Barrier-Free Outdoor Tubular Drinking Fountains

ADA FOUNTAINS

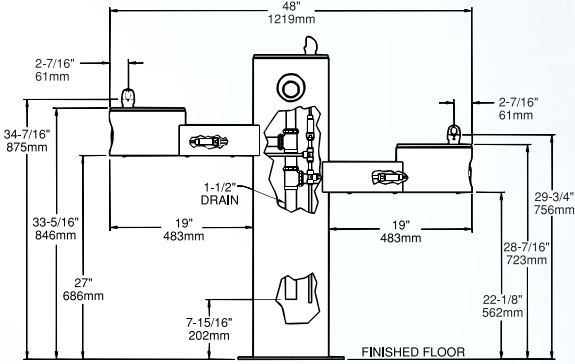

4430 Endura II™ Tubular Steel Triple Station Fountain

- Pushbuttons with self-closing valve
- Vandal-resistant bubblers
- Constructed of durable cold rolled steel
- Weather-resistant textured evergreen Endura™ finish standard
- Side basins meet requirements of ADA for adults and children
- Access panel features vandal-resistant screws
- Available with locking and non-locking hose bib



4430

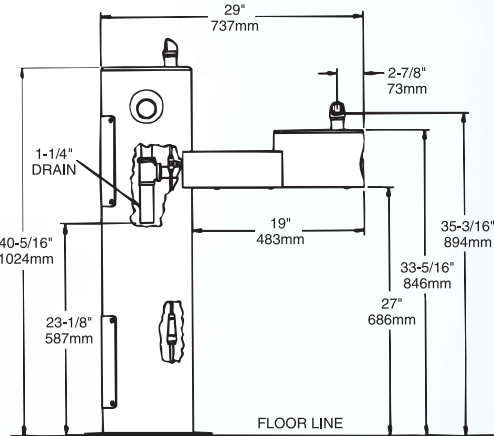

4420 Endura II™ Tubular Steel Barrier-Free Bi-Level Pedestal Fountain

- Pushbuttons with self-closing valve
- Vandal-resistant bubblers
- Constructed of durable cold rolled steel
- Weather-resistant textured evergreen Endura™ finish standard
- Side basin meets requirements of ADA
- Access panel features vandal-resistant screws
- Available with locking and non-locking hose bib
- Available with freeze-resistant valve
- Available with sanitary freeze-resistant valve



4420

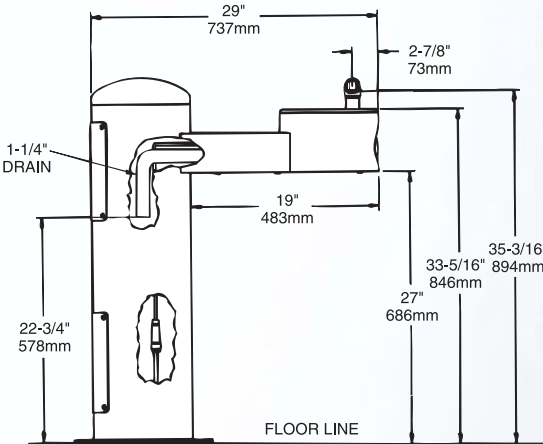

4410 Endura II™ Tubular Steel Barrier-Free Pedestal Fountain

- Front pushbutton with self-closing valve
- Vandal-resistant bubbler
- Constructed of durable cold rolled steel
- Weather-resistant textured evergreen Endura™ finish standard
- Front access panel features vandal-resistant screws
- Meets requirements of ADA
- Available with locking and non-locking hose bib
- Available with freeze-resistant valve
- Available with sanitary freeze-resistant valve



4410

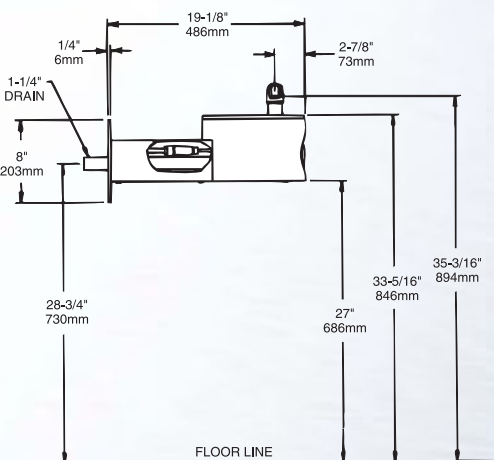

4405 Endura II™ Tubular Steel Wall-Mount Fountain

- Front pushbutton with self-closing valve
- Vandal-resistant bubbler
- Constructed of durable cold rolled steel
- Weather-resistant textured evergreen Endura™ finish standard
- Meets requirements of ADA
- Available with freeze-resistant valve



4405

All Endura II™ Tubular Fountains feature our E-Coat Immersion process, a unique procedure that coats the inside and outside of the fountain, for the ultimate in corrosion protection!

All Endura™ Fountains Are Now Available In 16 Colors! See Page 31

Endura™ Barrier-Free Outdoor Drinking Fountains

ADA FOUNTAINS



4710

4710 Barrier-Free Steel Pedestal Fountain With Single Basin

- Front pushbutton with self-closing valve
- Vandal-resistant Double Bubbler™
- Constructed of durable cold rolled steel
- Weather-resistant textured evergreen Endura™ finish standard
- Front access panel features vandal-resistant screws
- Ideal for parks, schools, office plazas, courtyards and recreation facilities
- Available with freeze-resistant valve system
- Meets requirements of ADA
- Size: 11" W x 26" D x 34" H
- Available with sanitary freeze-resistant valve

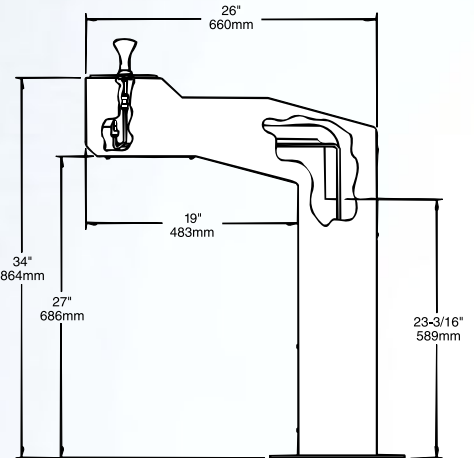

4720

4720 Barrier-Free Steel Pedestal Fountain With Two Basins

- Pushbuttons with self-closing valve
- Vandal-resistant Double Bubbler™
- Constructed of durable cold rolled steel
- Weather-resistant textured evergreen Endura™ finish standard
- Side basin meets requirements of ADA
- Access panel features vandal-resistant screws
- Available with freeze-resistant valve system
- Size: 11" W x 26" D x 38 1/2" H
- Available with sanitary freeze-resistant valve

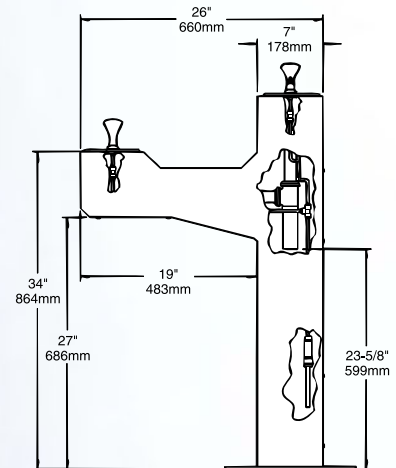

4705

4705 Barrier-Free Steel Wall-Mount Fountain

- Front pushbutton with self-closing valve
- Vandal-resistant Double Bubbler™
- Constructed of durable cold rolled steel
- Weather-resistant textured evergreen Endura™ finish standard
- Meets requirements of ADA
- Available with freeze-resistant valve
- Size: 11" W x 19" D

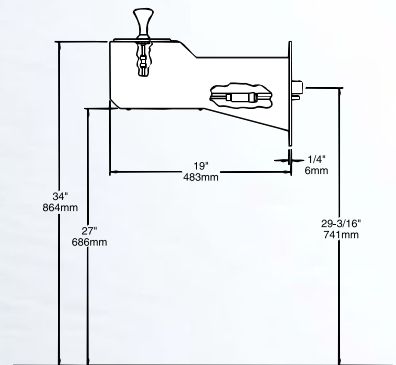

All Endura II™ Fountains feature our E-Coat Immersion process, a unique procedure that coats the inside and outside of the fountain, for the ultimate in corrosion protection!

All Endura™ Fountains Are Now Available In 16 Colors! See Page 31

Sierra™ Barrier-Free Outdoor Drinking Fountains

ADA FOUNTAINS



4590

4590 Barrier-Free Stone Pedestal Fountain

- Attractive weather-resistant Sierra™ stone aggregate
- Stainless steel basin
- Chrome-plated exposed fittings
- Easy access for wheelchairs
- Vandal-resistant Double Bubbler™
- Rust-resistant stainless steel access door with vandal-resistant screws
- Available with freeze-resistant valve system
- Available with sanitary freeze-resistant valve
- Meets requirements of ADA
- Size: 12³/₄" W x 29⁵/₈" D x 36" H to bubbler

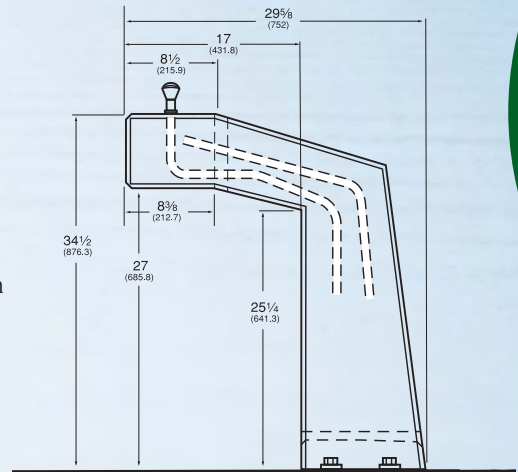

4595

4595 Barrier-Free Stone Pedestal Fountain with Two Basins

- Attractive weather-resistant Sierra™ stone aggregate
- Stainless steel basins
- Chrome-plated exposed fittings
- Easy access for wheelchairs
- Vandal-resistant Double Bubbler™
- Rust-resistant stainless steel access door with vandal-resistant screws
- Available with freeze-resistant valve system
- Extended basin meets requirements of ADA
- Available with sanitary freeze-resistant valve
- Size: 12" W x 31" D x 36" H to lower bubbler

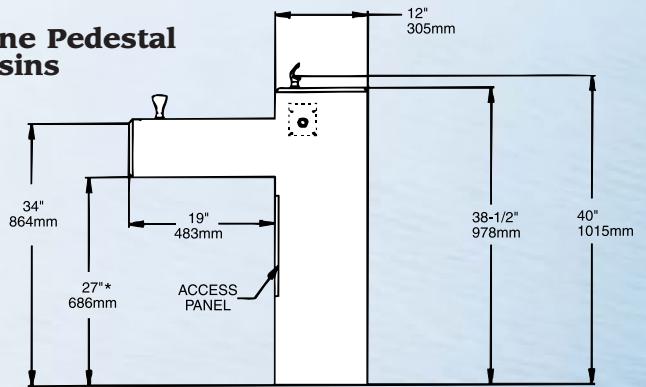

4593

4593 Barrier-Free Stone Wall-Mount Fountain

- Popular weather-resistant Sierra™ stone aggregate
- Stainless steel basin
- Chrome-plated exposed fittings
- Easy access for wheelchairs
- Vandal-resistant Double Bubbler™
- Ideal for indoor, as well as outdoor applications
- Available with sanitary freeze-resistant valve
- Meets requirements of ADA
- Size: 12³/₄" W x 17" D x 9" H

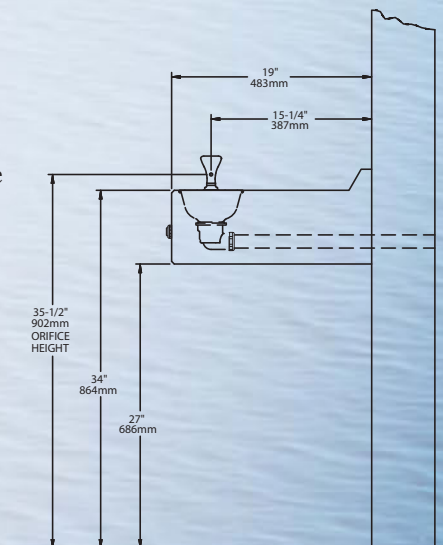

Standard Outdoor Drinking Fountains



4400 DB



4400

All Endura™
Fountains Are
Now Available
In 16 Colors!
See Page 31



4460



4715



4591

4400 DB Endura II™ Tubular Steel Upright Pedestal Fountain with Pet Fountain

- Pushbuttons with self-closing valve
- Vandal-resistant bubblers
- Constructed of durable cold rolled steel
- Weather-resistant textured evergreen Endura™ finish standard
- Available with locking and non-locking hose bib
- Pet fountain features slow drainage for easy drinking



4400 Endura II™ Tubular Steel Upright Pedestal Fountain

- Front pushbutton with self-closing valve
- Vandal-resistant bubbler
- Constructed of durable cold rolled steel
- Weather-resistant textured evergreen Endura™ finish standard
- Access panel features vandal-resistant screws
- Size: 10" W x 40 5/16" H
- Available with locking and non-locking hose bib
- Available with freeze-resistant valve
- Available with sanitary freeze-resistant valve



4460/4461 Endura II™ Tubular Yard Hydrant

- Available with non-locking (shown) and locking (4461) hose bib
- Constructed of durable cold rolled steel
- Weather-resistant textured evergreen Endura™ finish standard
- Not for use in sub-freezing temperatures

4715 Steel Upright Pedestal Fountain

- Front pushbutton with self-closing valve
- Vandal-resistant Double Bubbler™
- Constructed of durable cold rolled steel
- Weather-resistant textured evergreen Endura™ finish
- Access panel features vandal-resistant screws
- Available with freeze-resistant valve system
- Size: 11" W x 7" D x 36" H
- Available with sanitary freeze-resistant valve



4591 Sierra™ Upright Pedestal Fountain

- Attractive weather-resistant Sierra™ stone aggregate
- Stainless steel basin
- Chrome-plated exposed fittings
- Single stream pushbutton bubbler
- Enameled rust-resistant steel access door with vandal-resistant screws
- Size: 17" W x 14" D x 35 1/4" H

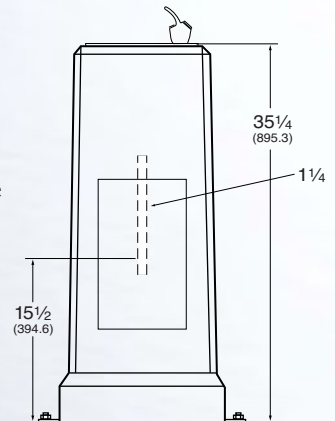
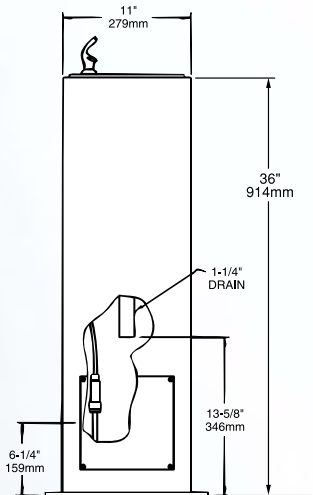
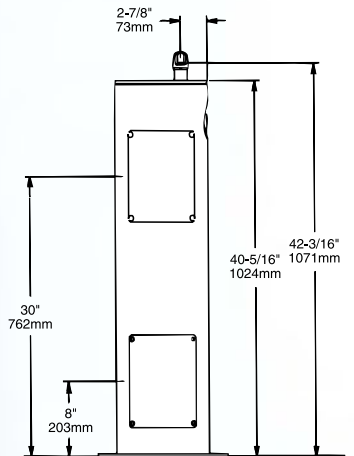
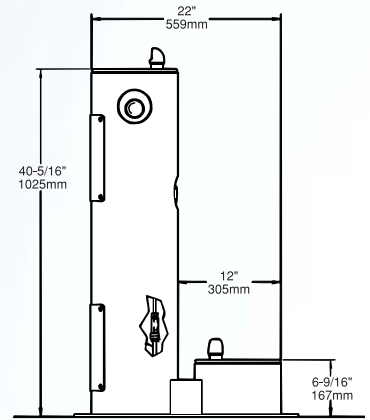

Cast Iron Outdoor Drinking Fountains

STANDARD FOUNTAINS

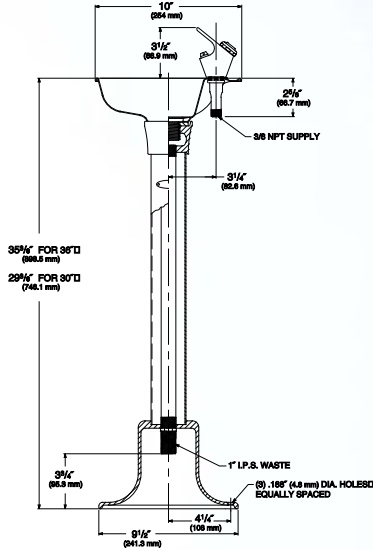

4616/4617 Pedestal Fountains

- Baked on forest green enamel finish
- Stainless steel basin
- Chrome-plated exposed fittings
- Automatic stream regulator
- 10" W x 6" D basin
- Removable chrome-plated brass strainer plate
- Single stream pushbutton projector
- Exposed water supply pipe (not included)
- 4616 - 30" fountain
- 4617 - 36" fountain



4617

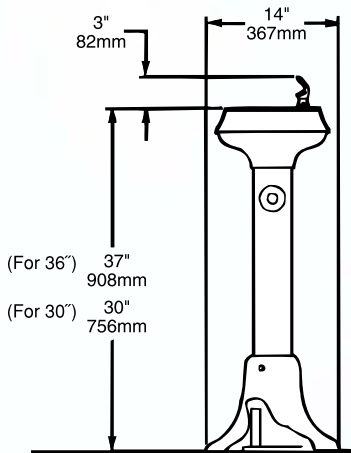

4880/4881 Freeze-Resistant Fountains

- Freeze-resistant valve buried below frost line
- Baked on forest green enamel finish
- Stainless steel basin
- Chrome-plated exposed fittings
- Automatic stream regulator
- Vandal-resistant Double Bubbler™
- 12" W x 8" D basin
- 4880 - 30" fountain
- 4881 - 36" fountain



4880

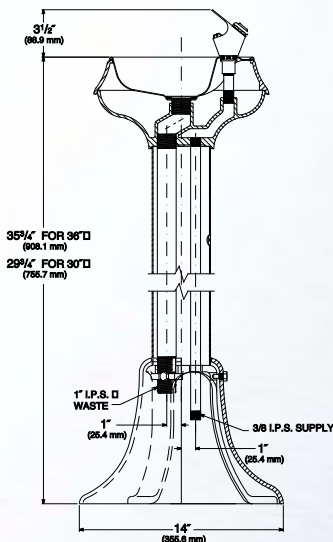

4520-68/4521-68 Fountains

- Baked on forest green enamel finish
- Stainless steel basin
- Chrome-plated exposed fittings
- Automatic stream regulator
- Single-stream pushbutton bubbler
- 12" W x 8" D basin
- 4520-68 - 30" fountain
- 4521-68 - 36" fountain



4520-68



HTICF

Ice Chilled Drinking Fountain

HTICF

- No more heavy, bulky coolers to clean & fill!
- Rugged green polymer cabinet
- Water is chilled through self-contained coils
- No electrical hook-up required
- Ice drawer slides out for easy filling
- Optional bubbler cover assembly
- Designed specifically for golf courses
- Meets No Lead definition of NSF/ANSI 61 only
- 18" W x 18" D x 43" H

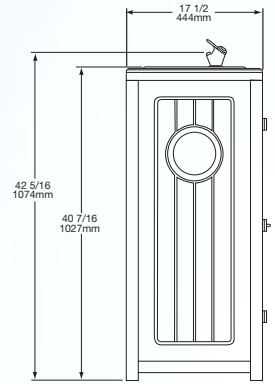

Stainless Steel Face-Mounted Drinking Fountain

HRFS

- Exclusive! Halsey Taylor *Double Bubbler™*
- Durable satin finish stainless steel
- Softly rounded corners
- Automatic stream regulator
- Available with freeze-resistant valve system
- 13" W x 12 1/8" D x 6 1/2" H



HRFS

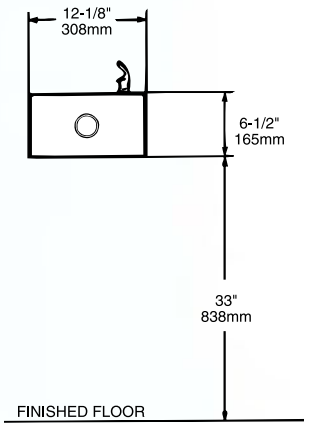

Molded Face-Mounted Drinking Fountain

5405

- Pushbutton bubbler
- Automatic stream regulator
- Durable molded material
- Neutral white finish
- 13 3/4" W x 17 1/8" D x 7 1/8" H



5405

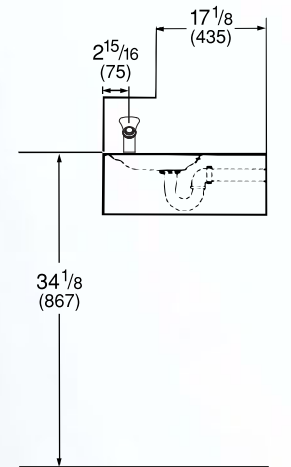

Sierra™ Stone Face-Mounted Drinking Fountain

4592

- Popular weather-resistant Sierra™ stone aggregate
- Stainless steel basin
- Chrome-plated exposed fittings
- Easy access for wheelchairs
- Vandal-resistant Double Bubbler™
- Ideal for indoor, as well as outdoor applications
- Available with freeze-resistant valve system
- 12 7/8" W x 11" D x 9" H



4592

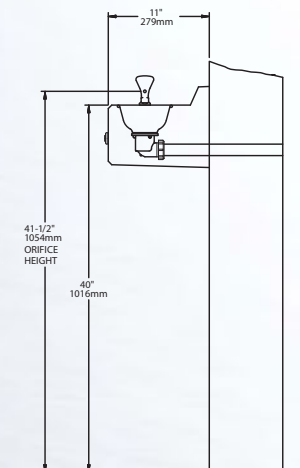

Fully Recessed Drinking Fountain and Cuspidor

STANDARD FOUNTAINS

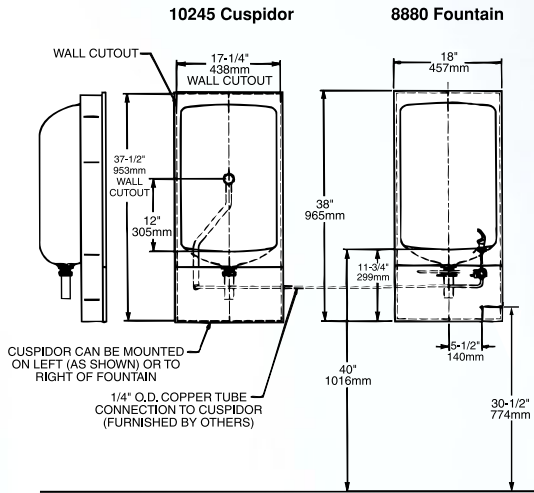

8880 Drinking Fountain • 10245 Cuspidor

- Fully recessed for uninterrupted corridor space
- Ideal for high-traffic areas
- Exclusive! Halsey Taylor *Double Bubbler™*
- Durable satin finish stainless steel
- Easy-to-install mounting frame
- Removable lower panel for easy service
- Automatic stream regulator
- Optional 10245 Cuspidor mounts on left or right side*
- Cuspidor size: 18" W x 10 3/8" D x 38" H

* Cuspidor water pressure must be 40 lbs. minimum



10245

8880

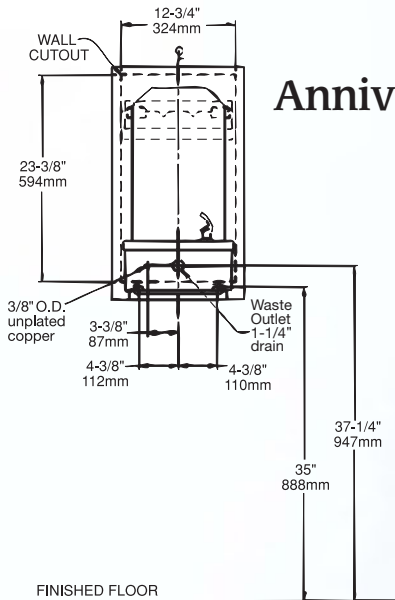

Anniversary Drinking Fountain

2634 Semi-Recessed Drinking Fountain

- Nostalgic traditional styling
- Solid one-piece White Marblyte™ non-porous polymer
- Semi-recessed design with smooth corners and edges
- Exclusive! Halsey Taylor *Double Bubbler™*



2634

Stainless Steel Drinking Fountain With Back Splash

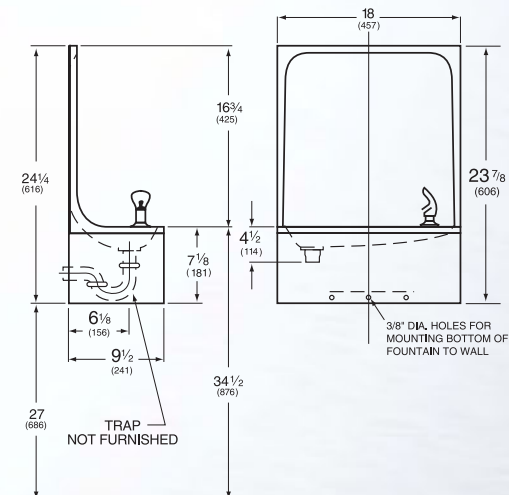

5701 Stainless Steel Drinking Fountain

- One-piece stainless steel backsplash and basin
- Exclusive! Halsey Taylor *Double Bubbler™*
- Front and side pushbars with raised letters for the visually impaired



5701

Multi-Station Drinking Fountains

STANDARD FOUNTAINS



7020

7020 Two Station Drinking Fountain

- One-piece construction
- Single-stream angle jet bubbler
- Built-in backsplash
- Durable satin finish stainless steel
- Automatic stream regulator
- Includes bottom cover plate
- Ideal for schools

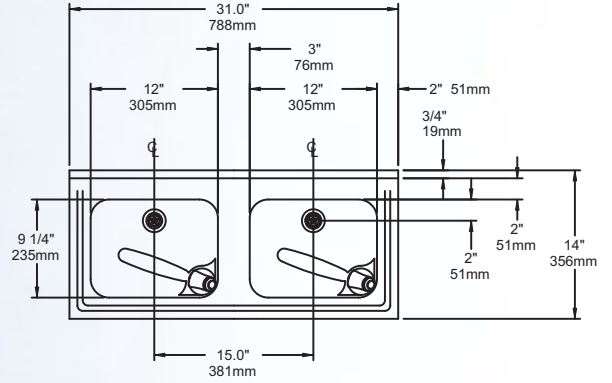
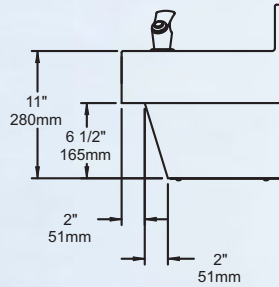

7030

7030 Three Station Drinking Fountain

- Unique three station design
- One-piece construction
- Single-stream angle jet bubbler
- Built-in backsplash
- Durable satin finish stainless steel
- Automatic stream regulator
- Includes bottom cover plate
- Ideal for schools

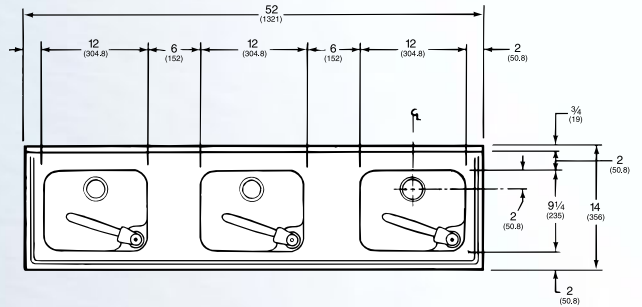
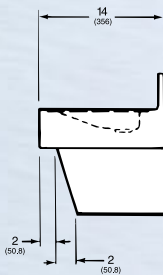

Drinking Fountain Kits

STANDARD FOUNTAINS

Use our kits to create your own countertop fountains as well as other applications.

All models feature:

- Durable satin finish stainless steel
- Chrome-plated exposed fittings
- Removable strainer plate
- Automatic stream regulator

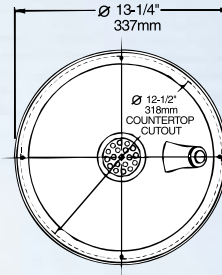

10000

10000

- Pushbutton chrome-plated single-stream bubbler
- 13 1/4" diameter, 1 3/4" deep



6000

- Pushbutton chrome-plated single-stream bubbler
- 12 1/4" W x 8 1/4" D x 3" H

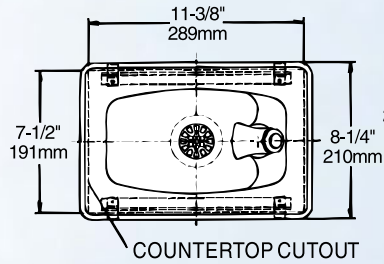

6000

6028

- Exclusive! Halsey Taylor *Double Bubbler™*
- Separate push button
- 22 1/2" W x 10 1/4" D x 2 7/8" H

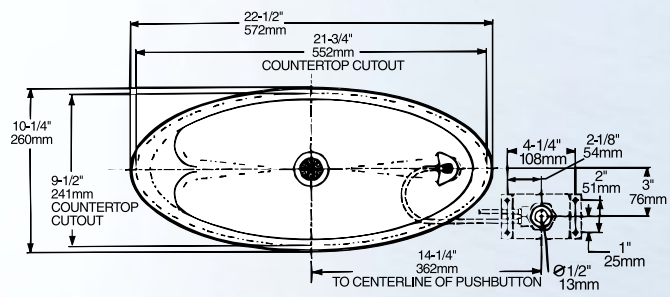

6028

Bracket Drinking Fountains

2501A

- Automatic stream regulator
- Pushbutton single stream bubbler
- Durable satin finish stainless steel basin
- Chrome plated exposed fittings
- Removable chrome plated strainer
- 10" W x 6" D x 3" H basin

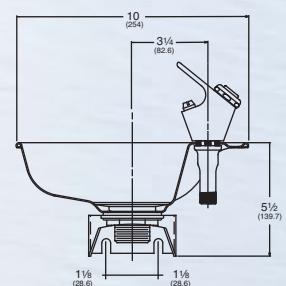

2501A

4540

- Automatic stream regulator
- Exclusive! Halsey Taylor *Double Bubbler™*
- Durable satin finish stainless steel basin
- Self-closing lever handle stop
- Chrome plated exposed fittings
- Removable chrome plated strainer
- 10" W x 6" D x 3" H basin

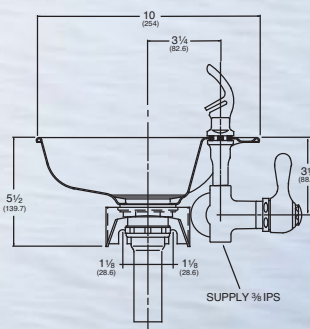

4540

For complete information, consult product specification sheets.

Remote Chillers



SJ8-Q

SJ8-Q Remote Chiller

- Adjustable thermostat – preset to 50° F
- Electrical leads 120V
- Heavy-duty galvanized steel construction
- Plumbing connections: 1/4" OD inlet and outlet



SJ10-Q

SJ1-Q Compact Chiller

Smaller chiller for point-of-use and under counter applications



SJ5-Q • SJ10-Q Remote Chillers

Powerful remote chillers that provide up to 10 GPH chilled water for large systems



SJ19-Q • SJ30-Q • SJ32W-Q Large Remote Chillers

Our most powerful remote chillers for up to 32 GPH



Chiller Accessories

- Mounting shelf for SJ8-Q
- Wall box and grill for SJ8-Q
- Wall box for SJ5, SJ10, and SJ19-Q
- Mounting shelf and cover for SJ5, SJ10, and SJ19-Q
- Stainless steel or platinum vinyl grill for SJ5, SJ10, and SJ19-Q



SJ32W-Q

Model	Rated GPH Cooled to	Rated Watt Usage	F.L. Amps	Condenser Cooling	Chiller Dimensions			Minimum Wall Opening Dimensions		
	50° F				Width	Depth	Height	Width	Depth	Height
SJ1-Q	1.5	155	1.7	Air	17 1/8"	6 5/16"	14"	-	-	-
SJ5-Q	5.7	230	2.5	Air	19 1/2"	7 7/8"	22"	21 1/2"	10 7/8"	25"
SJ8-Q	8	370	4.0	Air	13 1/2"	11 1/4"	18 1/2"	18 3/4"	13"	32"
SJ10-Q	9.6	535	5.8	Air	19 1/2"	7 7/8"	22"	21 1/2"	10 7/8"	25"
SJ19-Q	19	830	9.0	Air	23"	10 1/8"	25 3/4"	26 1/4"	14"	30"
SJ30-Q	29.5	1290	14.0	Air	33 1/4"	13 3/4"	16 1/8"	-	-	-
SJ32W-Q	31.9	1012	16	Water	33 1/4"	13 3/4"	16 1/8"	-	-	-



2507A



2509



3041



Double Bubbler™



Easy-Flex™ Bubbler



Bubbler Cover



Vandal-Resistant Bubbler

Fountain Heads and Bubblers

2507A 1/4" NPT Supply



2509 3/8" NPT Supply

- Double Bubbler™ projector
- Chrome-plated fittings
- Self-closing lever handle valve
- Removable shutoff seat
- Volume regulator

45709C Double Bubbler™

- Exclusive patented design
- Chrome-plated unleaded brass

45392C Vandal-Resistant Bubbler

- Chrome-plated heavy duty unleaded brass
- One-piece design features integrated orifice
- Keys into position to prevent rotation and tampering

Use 98030C when ordering

3041 3/8" NPS Supply



- Chrome-plated unleaded brass
 - Single-stream angle jet projector
 - Self-closing pushbutton shutoff
 - Integral automatic stream regulator
- Use A54881 when ordering

55905C Easy-Flex™ Bubbler

- Flexes upon impact to help prevent serious injury
- Ideal for coolers and fountains servicing children

Bubbler Cover Assembly

- 3/8" NPS Supply
- Two-piece design with integrated orifice
- Prevents possible contamination from hazardous materials

Use 15037C when ordering

Water Filtration Kits

Aqua Sentry Cyst and Lead Reduction Filter HWF142

- Removes lead, cyst, chlorine class I and particulate class I
- Size: 10.13" H x 2.10" D
- Designed for use in Voyager™ units, but fits most Halsey Taylor models where **space is a concern**

56191C Replacement Filter for Aqua Sentry

Water Sentry VII Lead Reduction Filter HWF172

- Removes lead, cyst, chlorine class I and particulate class I
- Size: 12½" H x 3¼" D
- Fits most Halsey Taylor units

55897C Replacement Filter for Water Sentry VII



Aqua Sentry Model HWF142

Water Sentry VII Model HWF172

ACCESSORIES

Kits And Accessories

Universal Vandal-Resistant Kit 98030C

- For use on most Halsey Taylor units to make them more tamper-resistant
- Vandal-resistant bubbler (replaces standard bubbler)
- Assorted tamper-resistant screws, washers and miscellaneous pieces

98032C Vandal-Resistant Small Drain Kit

(Not Pictured)

- Modifies HRF series units with 1¼" drain opening to make them more vandal-resistant

Vandal-Resistant Pinned Torx Bits

- 75520C T-25
- 75523C T-20

09855 Vandal-Resistant Drain Kit (Not Pictured)

- Modifies units with 2 7/8" drain opening to make them more vandal-resistant

15213 Sump Pump Kit (Not Pictured)

- Pumps waste water from cooler to drain
- Quiet ½ HP, 115V, 60 cycle motor
- Pumps maximum 28 GPH at 40-foot height
- Available for SCWT and S Series coolers only

Foot Pedal Kit 14703 (Not Pictured)

- Allows on site installation of foot pedal in minutes on most SCWT series floor-standing Halsey Taylor water coolers

HTRP2130 Remodeling Panel

- Trim piece for HTV8, HAC CHILD, and HVR Series models
- Attractive gray color blends with any decor
- Constructed of durable, rust and corrosion resistant ABS
- Allows for increased retrofit applications
- Size: 30" H x 21" W

APHT Access Panel Kit (Not Pictured)

- For units with traps behind wall

Cane Touch Apron Kits (Not Pictured)

- Available for HAC, HRF, HTV, HDF, HVR and OVL-II Models

97887C Hose Bib Kit (Not Pictured)

- Accessory with hose connection for supplying non-potable water. For use on Endura II™ 4400 Series fountains with floor mounted base
- *Not for use on freeze-resistant fountains*

97889C Locking Hose Bib Kit (Not Pictured)

- Same as above but with lockable protective shroud to minimize vandalism

97890C Direct Bury Adaptor (Not Pictured)

- For use with Tubular Outdoor Fountains



98030C Universal Vandal-Resistant Kit



Remodeling Panel



96852CA Universal Glass Filler Kit

Glass Fillers

Universal Glass Filler Assembly Kit 96852CA



- Includes all necessary pieces for field installed replacement
- Factory preparation recommended
- 8 1/8" high, bright polished stainless steel gooseneck spout
- Push-down lever handle
- 3/8" IPS supply

Additional Glass Fillers only include:



- 2408 Chrome-plated factory installed pushbutton glass filler (for 8880 and RC8)

For complete information, consult product specification sheets.

In-Wall Mounting Systems

MLP100

- Single in-wall mounting frame
- For HTV, HAC & HVR series

MLP200

- Bi-level in-wall mounting frame
- For HTV, HAC & HVR series

MPW100

- Single in-wall mounting plate
- For OVL series

MPW101

- In-wall mounting plate
- For HDFF & HRF series single models

MPW200

- In-wall mounting plate
- For OVL, HDFF & HRF series bi-level models

MPW201

- In-wall multi-station mounting plate
- For 7120 Fountain

ML100

- In-wall support legs (used with MPW series wall plates)



MLP100

MLP200

MPW100

NEW!

Water Cooler Feature Guide

Type of Cooler	FEATURES AND AVAILABLE OPTIONS										AVAILABLE FINISHES						
	Series	ADA Compliant	Electronic Eye	220V Option	Less Refrigeration	Glass Filler	Easy-Flex™ Bubbler	Vandal Resistant Kit	Sump Pump	Water Filter	Platinum	Slate	Almond	Stainless Steel	Aztec Gold	Marblyte™	Two-Tone Gray
Barrier Free	HTV	●	●	●	●	●	●	●		●							●
	HAC	●	●	●	●	●	●	●		●			●				
	HVR	●		●	●					●			●				
	WC	●	●	●	●		●	●		●	●	●	●				
Refrigerated Fountains	HRF	●	●*	●*	●		●	●		●			●			●	
	OVL-II™	●		●	●		●	●		●			●	●	●		
	BFMR	●		●	●	●	●	●		●			●				
Wall Mounted	WM			●	●	●	●	●		●	●	●	●				
	SW			●	●	●	●	●		●	●	●	●				
Fully Recessed	RC			●	●	●	●	●		●			●				
Simulated Recessed	HBW			●	●		●	●		●	●	●	●				
Deluxe Floor Standing	SCWT**			●	●	●	●	●	●	●	●	●	●				
	XP8W-Q					●		●		●			●				
Outdoor Coolers	HOF			●						●			●				
Economy	S Series			●	●	●		●	●	●	●		●				
Remote Chillers	SJ			●						●							

* Stainless Steel models only ** Available with foot pedal kit

Important Note: Minimum 40 psi supply line pressure required in special circumstances when both sides of a bi-level model are in use simultaneously, to ensure adequate stream height. Use of a water filter in this situation is not recommended. Does not apply to non-refrigerated units.

“Rule of Thumb” Cooler Sizing

To select the proper Halsey Taylor water cooler for your specific environment, follow this simple procedure.*

- Determine the number of people to be served.
- Find the “Persons served per GP” figure for your environment from the chart at right.
- Divide the number of people to be served by the

“Persons served per GPH” figure to determine the total rated GPH required of the Halsey Taylor cooler or coolers you select.

Example: A light manufacturing environment, (15 persons per GPH) with 120 people present: $120 \div 15 = 8.0$
Therefore, you should select a Halsey Taylor water cooler with a rated capacity of 8.0 GPH, or two 4 GPH coolers.

*Based on 50°F drinking water at 90° room temperature and 80° inlet water temperature.

Environment	Persons Served Per GPH
Offices/Schools/ Hospitals/Stores/Hotels	25
Light Manufacturing	15
Heavy Manufacturing	12
Hot, Heavy Manufacturing	10

Water Cooler Color Guide

Complement Any Decor With Colorful Ideas From Halsey Taylor!

Halsey Taylor has practical, as well as beautiful finish and color options. From our standard vinyl colors and premium metal finishes, to our stunning Aztec Gold and unique solid Marblyte™, Halsey Taylor offers colorful ideas for today's vibrant and distinct environments!



**Now Available
In 16 Colors!**

Endura™ Drinking Fountains Color Guide

Halsey Taylor Endura™ and Endura™ II Steel Drinking Fountains are now available in a choice of 16 colors! In addition to our standard textured evergreen finish, choose from 15 new exciting color options all featuring a textured river finish.



Evergreen



Moss



Slate



Blue



Navy



Purple



Terracotta



Red



Brown



Maroon

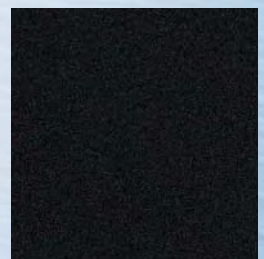

Black



Orange

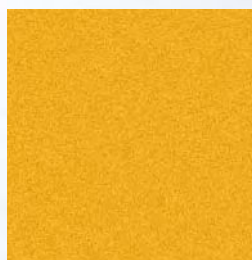

Yellow

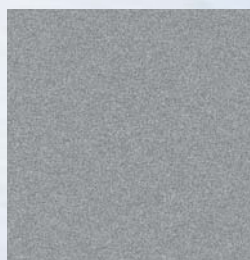

Gray



Beige



Neutral

Halsey Taylor has the ideal model for almost any application...indoors and outdoors! Just as we have since 1912, we will continue to strive to be the pioneer for water cooler and drinking fountain innovation. We welcome your comments & suggestions.



Continued product improvements makes specifications and products subject to change without notice.



Halsey Taylor[®]

Satisfying Thirsts Since 1912.

Note: This catalog supercedes all previously printed catalogs.



Printed on recycled paper

E-mail us at sales@halseytaylor.com

Visit us on the World Wide Web at halseytaylor.com

Form No. HTFLC10/08

2222 Camden Court, Oak Brook, Illinois 60523 Telephone: 630.574.3500 Fax: 630.574.3503

Printed in U.S.A.